

ITEM	QTY	DESCRIPTION	ITEM	QTY	DESCRIPTION	ITEM	QTY	DESCRIPTION
1	1	3" FNPT INLET	8	2	PVC OIL SKIMMER	15	1	OIL STORAGE TANK
2	1	3" FNPT OUTLET	9	3	REMOVABLE COVERS	16	4	LIFTING LUGS
3	2	2" FNPT OIL OUTLET	10	1	OIL STOP WEIR	17	2	SUPPORT CHANNEL FOR COVERS
4	3	2" FNPT VENT	11	1	ADJ. OVERFLOW WEIR	18	1	COALESCING MEDIA HOLD DOWN
5	4	1" FNPT DRAIN	12	42	PLATES (EQ. SPACED 1" O.C.)			
6	2	2" FNPT SLUDGE DRAIN	13	24	CU. FT. COALESCING MEDIA			
7	2	LEVEL SENSOR PORT 2" NPT	14	1	CLEAN WATER CHAMBER			

SHIPPING WEIGHT	2550 LBS
OPERATING WEIGHT	10,615 LBS
SEPARATOR VOLUME	968 GALLONS
EFFLUENT TANK VOLUME	250 GALLONS
SLUDGE VOLUME	85 GALLONS
COALESCING AREA	24 FT <sup>2</sup>
OPT. PRODUCT TANK VOL	75 GALLONS

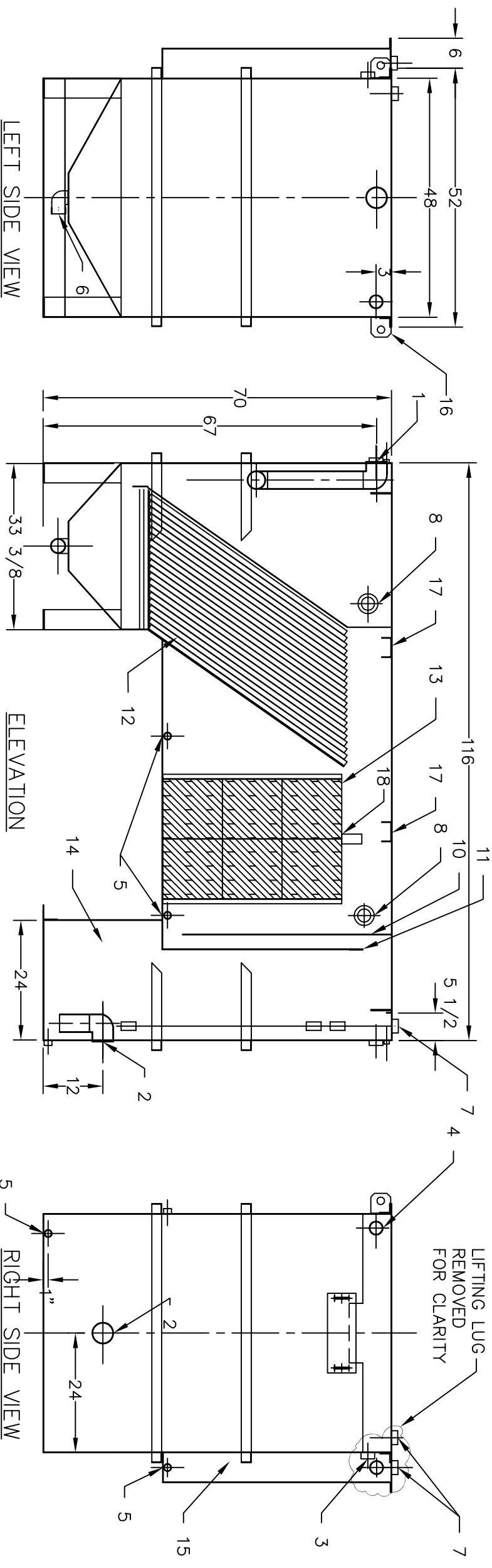

**NOTES**

1. MATERIAL: 11 GAUGE 304SS.
2. GASKET: 1/4" THICK X 2" WIDE NEOPRENE.
3. HARDWARE: 18-8 STAINLESS STEEL
4. INTERNAL PIPE SCH 80 PVC – SLOTTED PIPE SKIMMERS.
5. COVERS ARE 3/16" THICK 5052-H32 ALUMINUM.
6. MEDIA TO BE REMOVABLE IN 12" X 12" X 12" BLOCKS.
7. CLARIFIER PLATE CONSTRUCTION 22 GAUGE 304SS.

1	ISSUED FOR CLIENT APPROVAL	12/28/10	PND
REV.	DESCRIPTION	DATE	INIT.

**JDI, INC.**

Water Treatment Systems

**GENERAL ARRANGEMENT**

**SPT-50-1P**

PROJECT:	FILE: SPT-50-1P	DATE: 10/15/14
REF:	SCALE: 1/2" = 1'	CHKD. BY:
THIS DRAWING IS PROPERTY OF JDI INC. AND MUST NOT BE REPRODUCED OR DISTRIBUTED WITHOUT WRITTEN PERMISSION.		
	REV: 1	