

ITEM	QTY	DESCRIPTION	ITEM	QTY	DESCRIPTION
1	1	2" FNPT INLET	8	1	REMOVABLE COVER
2	1	2" FNPT OUTLET	9	1	OIL STOP WEIR
3	1	2" FNPT OIL OUTLET	10	1	ADJ. OVERFLOW WEIR
4	2	2" FNPT VENT	11	0	NOT USED
5	2	1" FNPT DRAIN	12	0	OPT. SIGHT GLASS PORTS
6	1	COALESCING PLATES	13	0	OPTIONAL PRODUCT TANK
7	1	PVC OIL SKIMMER	14	0	NOT USED

SHIPPING WEIGHT	250 LBS
OPERATING WEIGHT	1210 LBS
SEPARATOR VOLUME	80 GALLONS
EFFLUENT TANK VOLUME	30 GALLONS
SLUDGE VOLUME	4 GALLONS
COALESCING AREA	2 FT ³
OPT. PRODUCT TANK VOL	40 GALLONS

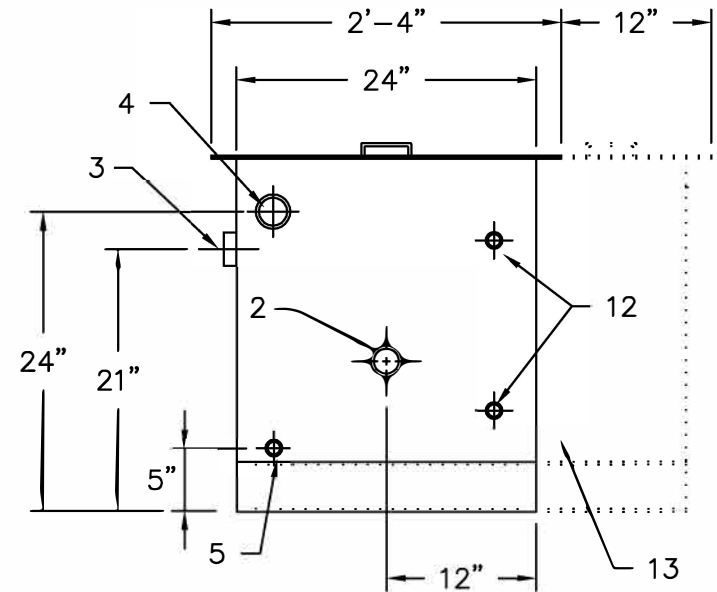
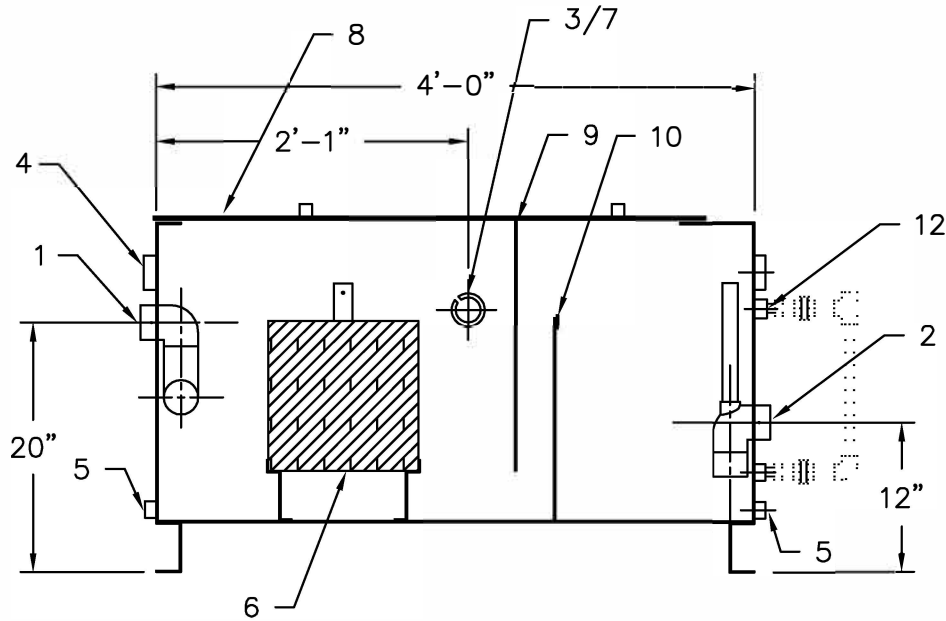

NOTES

1. MATERIAL: 12 GAUGE 304SS.
2. GASKET: NEOPRENE.
3. HARDWARE: 18-8 STAINLESS STEEL
4. INTERNAL PIPE SCH 80 PVC

REV.	DESCRIPTION	DATE	INIT.
WASHBAYSOLUTIONS.COM			
Water Treatment Systems			
GENERAL ARRANGEMENT		DRN. BY: PMD	
MODEL WB-GS-2		CHKD. BY:	
PROJECT:		DATE: 1/31/00	
REF:	FILE: WB-GS-2.DWG	SCALE: 3/4" = 1'	
THIS DRAWING IS PROPERTY OF WASHBAYSOLUTIONS. AND MUST NOT BE COPIED, LOANED OR DISTRIBUTED WITHOUT WRITTEN PERMISSION.			REV: A