

ITEM	QTY	DESCRIPTION	ITEM	QTY	DESCRIPTION
1	1	4" FNPT INLET	8	1	REMOVABLE COVER
2	1	4" FNPT OUTLET	9	1	OIL STOP WEIR
3	1	2" FNPT OIL OUTLET	10	1	ADJ. OVERFLOW WEIR
4	2	2" FNPT VENT	11	0	NOT USED
5	2	1" FNPT DRAIN	12	0	OPT. SIGHT GLASS PORTS
6	1	COALESCING PLATES	13	0	OPTIONAL PRODUCT TANK
7	1	PVC OIL SKIMMER	14	0	LIFTING LUGS

SHIPPING WEIGHT 790 LBS
 OPERATING WEIGHT 5830 LBS
 SEPARATOR WEIGHT 630 GALLONS
 EFFLUENT TANK VOLUME 100 GALLONS
 SLUDGE VOLUME 12 GALLONS
 COALESCING AREA 24 FT²
 OPT. PRODUCT TANK VOL 120 GALLONS

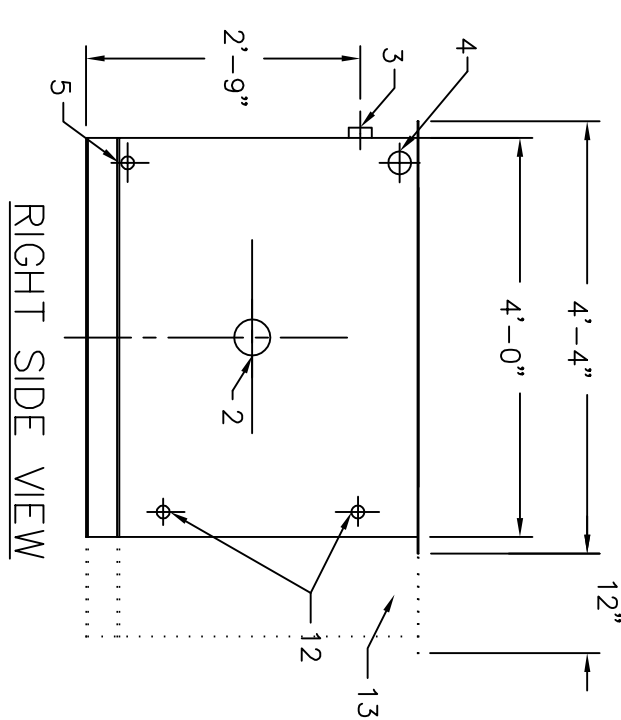
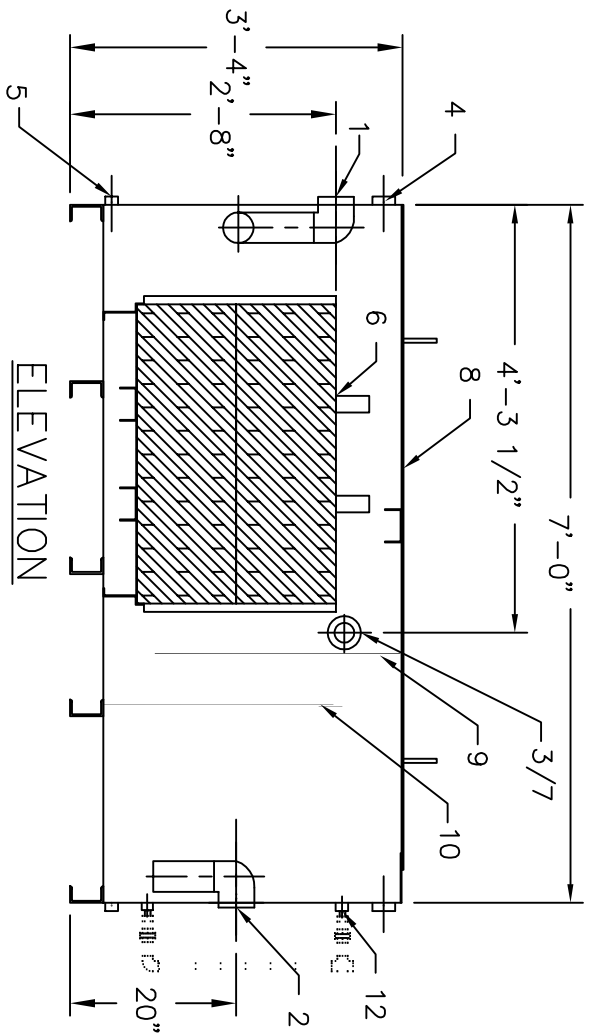

NOTES

1. MATERIAL: 11 GAUGE 304SS.
2. GASKET: NEOPRENE.
3. HARDWARE: 18-8 STAINLESS STEEL
4. INTERNAL PIPE SCH 80 PVC

REV.	DESCRIPTION	DATE	INIT.
WASHBAYSOLUTIONS.COM Water Treatment Systems			
GENERAL ARRANGEMENT MODEL WB-AG-4			
PROJECT:	FILE: WB-AG-4	DATE: 05/02/08	SCALE: 1/4" = 1'
REF:	DRN. BY: PND	CHKD. BY:	REV: 0
<small>THIS DRAWING IS PROPERTY OF B.I. INC. AND MUST NOT BE COPIED, LOANED OR DISTRIBUTED WITHOUT WRITTEN PERMISSION.</small>			