

ITEM	QTY	DESCRIPTION	ITEM	QTY	DESCRIPTION
1	1	3" FNPT INLET	8	1	REMOVABLE COVER
2	1	3" FNPT OUTLET	9	1	OIL STOP WEIR
3	1	2" FNPT OIL OUTLET	10	1	ADJ. OVERFLOW WEIR
4	3	2" FNPT VENT	11	0	OPTIONAL MESH PAD
5	3	1" FNPT DRAIN	12	0	OPT. SIGHT GLASS PORTS
6	1	COALESCING PLATES	13	0	OPTIONAL PRODUCT TANK
7	1	PVC OIL SKIMMER	14	0	LIFTING LUGS

SHIPPING WEIGHT	570 LBS
OPERATING WEIGHT	4330 LBS
SEPARATOR VOLUME	470 GALLONS
EFFLUENT TANK VOLUME	75 GALLONS
SLUDGE VOLUME	9 GALLONS
COALESCING AREA	18 FT ³
OPT. PRODUCT TANK VOL	120 GALLONS

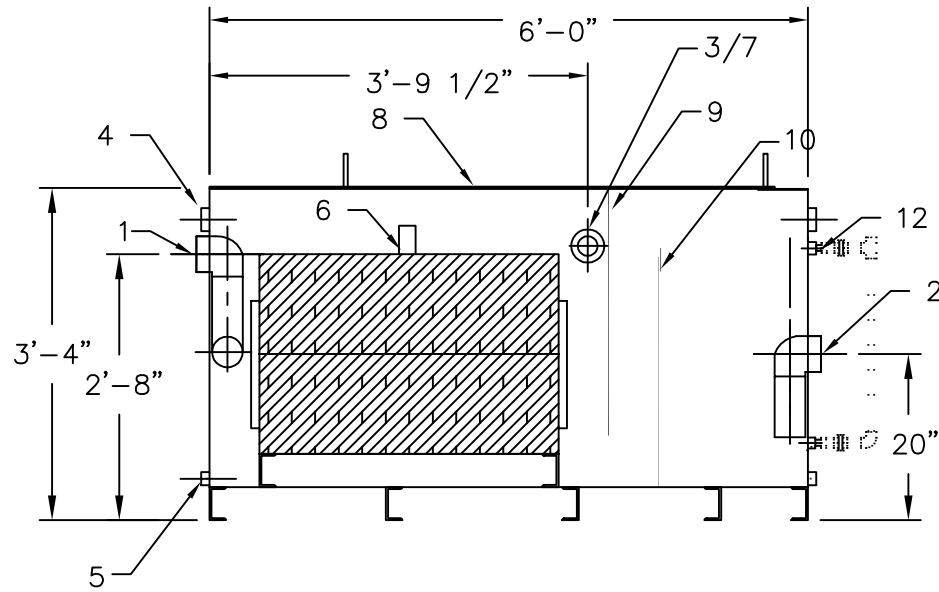

ELEVATION

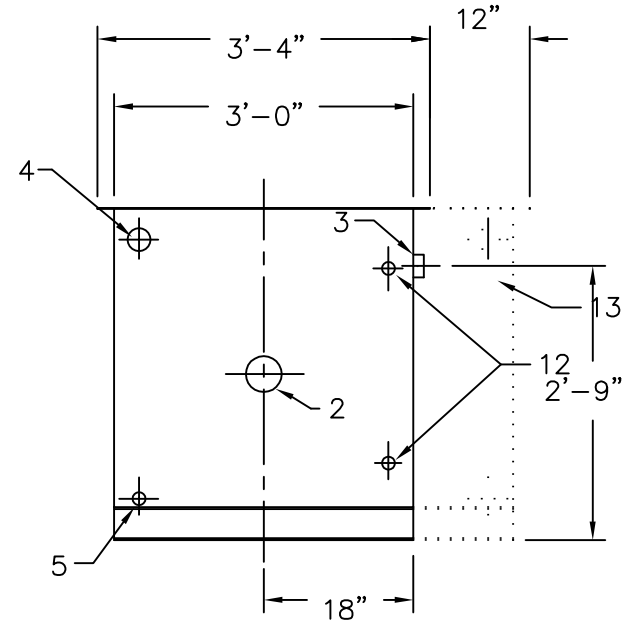

RIGHT SIDE VIEW

NOTES

1. MATERIAL: 12 GAUGE 304SS.
2. GASKET: NEOPRENE.
3. HARDWARE: 18-8 STAINLESS STEEL
4. INTERNAL PIPE SCH 80 PVC

REV.	DESCRIPTION	DATE	INIT.
WASHBAYSOLUTIONS.COM Water Treatment Systems			
GENERAL ARRANGEMENT MODEL WB-AG-3		DRN. BY: PMD	CHKD. BY:
PROJECT:		DATE: 10/28/09	SCALE: 1/4" = 1'
REF:	FILE: AG3	REV: 0	
THIS DRAWING IS PROPERTY OF JDI INC. AND MUST NOT BE COPIED, LOANED OR DISTRIBUTED WITHOUT WRITTEN PERMISSION.			