

Description

The DELZONE® AGW-0500 is a self-contained mobile ozone sanitation system that provides ozone-enriched cold water on demand for hard surface sanitation and direct food contact applications. The AGW-0500 ships “plug and play” ready and provides 9.5 GPM water flow with a residual ozone dose of approximately 2.0 PPM at the nozzle. A 50’ foot ozone delivery hose and spray wand are included with the system.

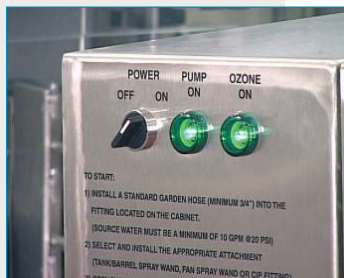

Benefits of Ozone Sanitation

- FDA, USDA, and EPA approved antimicrobial agent
- USDA National Organic Program allowed ingredient
- NSF Third-party validated for antimicrobial reduction
- Hard surface sanitation and direct food contact
- No-rinse, no-residual, continuous or on-demand sanitation
- Relative sanitizing strength - 2 PPM ozone solution is equal to 400 PPM chlorine or quaternary ammonia
- Reduces or eliminates potable water rinse steps and overall water use
- Non-corrosive sanitation solution
- No unpleasant odor

Features of DELZONE® AGW-0500

- Integrated DEL Ozone Safety Management System
- Automatic plug-and-play operation
- 9.5 GPM ozone-enriched water flow
- Dependable, reliable, low-maintenance operation
- Stainless steel, NEMA-4X enclosure
- NSF validated for anti-microbial efficacy and worker safety
- NSF registered (#132680) for hard surface sanitation
- NSF International White Book listed-proprietary substance and nonfood compound for no-rinse surface sanitation



For more information please visit us at www.delozone.com

PO Box 4905, San Luis Obispo, California, 93401

800.676.1335 ext. 238 fax: 805.541.8459

o3info@delozone.com



Specifications

Ozone Output	8.0 grams/hr
Residual Ozone Dose at Nozzle	2.0 PPM (approx.)
Water Flow Rate	9.5 GPM
Nozzle Pressure	20 PSI
Power Requirements	115VAC, 60Hz, 18A
Supply Water Temp.	40F - 80F
Supply Water Press.	20 PSI (min)
Supply Water Flow	9.5 GPM (min)

Standard Configurations

AGW-0500 (base) Mobile Ozone Surface Sanitation System

- Cart-mounted mobile system
- Long fan spray wand
- 50' ozone delivery hose with shut-off valve
- 50' power cord

AGW-0500-240 Mobile Ozone Surface Sanitation System

- All the features of our base AGW-0500 Ozone Surface Sanitation System
- Built-in transformer for 240V, 50/60Hz operation

Dimensions

AGW-0500

Weight: 200 lbs.

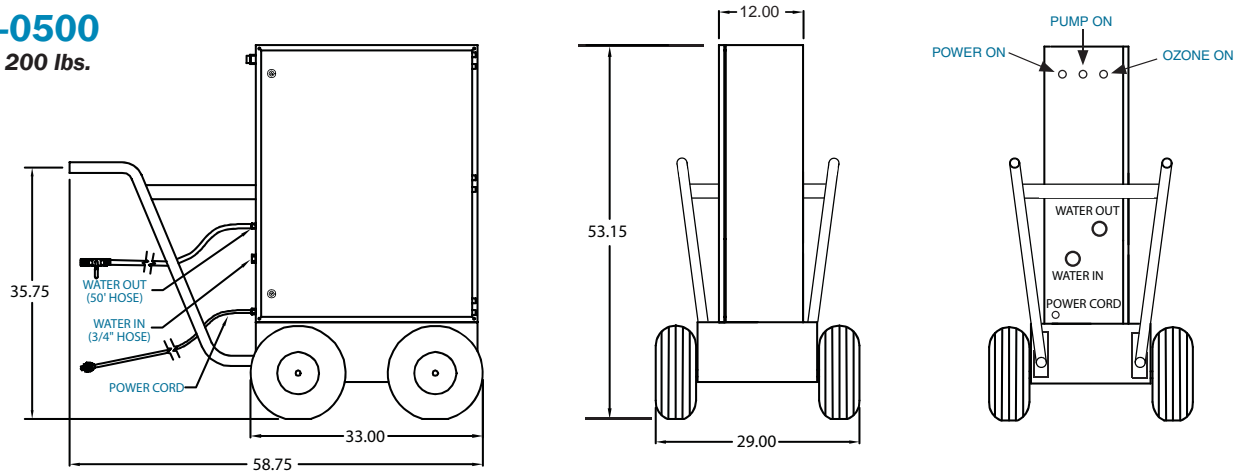

Accessories



AGW-0270
Fan Spray Wand



AGW-0150
CIP Adapter



AGW-0250
Wine Barrel Wash Wand

AGW-0280
Tank Wash Wand



MPI-0380
Hot Water Protection Device
(Installs at water inlet)

For more information please visit us at www.delozone.com

PO Box 4905, San Luis Obispo, California, 93401

800.676.1335 ext. 238 fax: 805.541.8459

o3info@delozone.com